

# FOCAL X : A TEST FACILITY FOR X-RAY TELESCOPES

J.Ph. Tock, J.P. Collette, A. Cucchiaro, I. Domken, Y. Stockman

Centre Spatial de Liège - Université de Liège  
Parc Industriel du Sart Tilman, Avenue du Pré-Aily  
B-4031 ANGLEUR-LIEGE, Belgium  
phone : + 32 4 367 66 68, fax : + 32 4 367 56 13, E-Mail : CSLULG@vm1.ulg.ac.be

A. Vignelles, Ph. Kletzkine

ESA/ESTEC  
PO BOX 299, 2200 AG Noordwijk, The Netherlands  
phone : + 31 71 565 65 65, fax : + 31 71 565 4895

## ABSTRACT

The X-ray Multi-Mirror Mission is one of the four "Cornerstone" projects in the ESA Long Term Programme for Space Science. A vertical test facility to assess the optical quality of individual XMM optics and of each of the complete telescopes has been built at the Centre Spatial de Liège. The main feature of this facility is its vertical optical axis in order to avoid any mechanical deformation of the mirrors induced by earth gravity. This paper presents FOCAL X main characteristics : the test chamber is a cylindrical vessel of 4.5 m diameter and 12 m height as required by optical and geometrical constraints ; the optical stimuli at various wavelengths : visible, EUV, and X-ray ; the different detectors : EUV CCD, X CCD, solid state detector, photo-multipliers, visible CCD ; the optics comprising a Cassegrain 800 mm diameter collimator, an off-axis parabola collimator and a pencil beam. FOCAL X operates under vacuum (pressure  $\leq 5 \cdot 10^{-4}$  Pa) and under clean environment (class 100).

Keywords : Test facility, X-ray, EUV, XMM

## 1. INTRODUCTION

The X-ray Multi-Mirror (XMM) Mission is the second "Cornerstone" project of ESA's Horizon 2000 Long-Term Science Programme. Within the framework of the development of X-ray telescopes such as XMM, several tests are mandatory to check and characterise their optical performance.

As previously explained<sup>[1,2]</sup>, the image quality test must be performed with the telescope optical axis vertically aligned in order to minimise the deformation of the mirror shells/spider assembly under the effect of the gravity. A dedicated facility has been designed and built at the Centre Spatial de Liège (CSL), named FOCAL X : acronym for Facility for Optical CALibration at Liège. Although this facility has been developed for the XMM satellite, various general

capabilities are provided by this powerful tool and are described in this paper.

## 2. FACILITY DESCRIPTION

The general layout of the facility is given in figure 1. It is mainly divided into three channels, each providing an optical beam with specific characteristics and other equipment shared by these channels. The overall height of the facility is 30 m.

### 2.1. Vacuum chambers

The main vacuum chamber, with a vertical axis, has a 4.5 m diameter and a 12 m height ; it is realised in ANSI 304 L stainless steel. The inner and outer surfaces are micro-blasted. The wall thickness is 15 mm. Weldings are continuous on vacuum side and non-continuous on external side to easily perform helium leak tests. The main vessel is divided into four sections. The tightness between the different sections is performed by outbaked double O-rings Viton seals and an interseal pumping system is installed. Flanges are distributed around the chamber to allow electrical connections and fluids feedings.

Five liquid nitrogen loops are implemented : three for the detectors cooling, one for the cold trap and one for thermal tests. Provision is made for the possible installation of additional loops in case of need, for thermal testing (Thermal Balance - Thermal Vacuum for instance).

The EUV annexed vacuum chamber is divided in two parts ; possible to open like Russian dolls. This allows easy access to the inside for possible repairs or upgrades.

The X-ray collimator vacuum chamber is a parallelepipedic vacuum chamber. One side is removable to provide easy access to the X-ray collimator mirror.

Three isolated small chambers are built for the sources and are equipped with their own differential pumping system.

figure 1

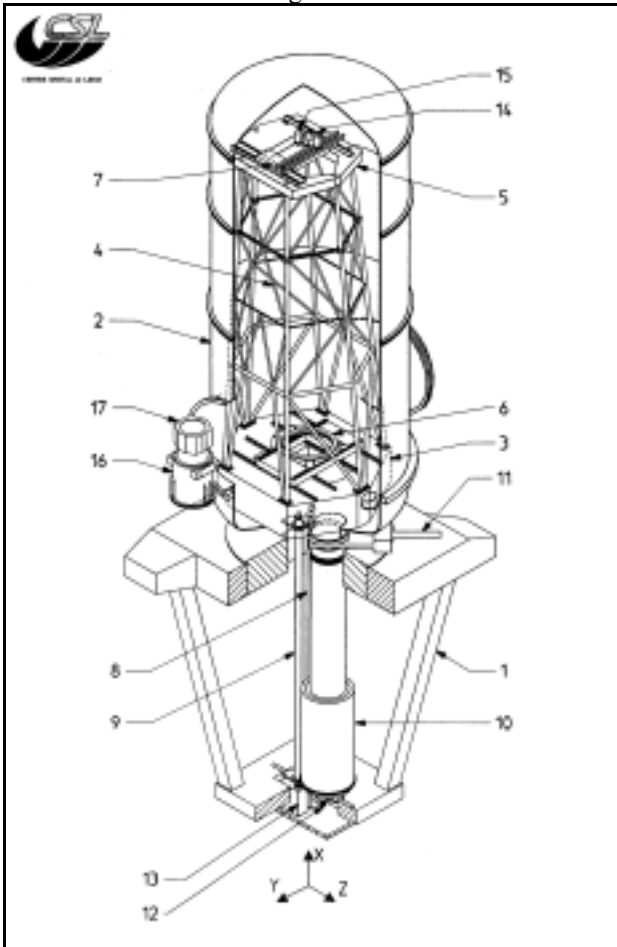

1. Seismic block, 2. Vacuum vessel, 3. Optical bench, 4. Tower, 5. Detector optical bench, 6. Specimen mechanisms, 7. Detectors mechanisms, 8. X collimated beam, 9. X pencil beam, 10. EUV channel, 11. Valve, 12. EUV source, 13. X-ray sources, 14. EUV detector, 15. X-ray detectors, 16. MASP, 17. Telescope

## 2.2. Pumping system

The general pumping system is schematised in figure 2 with the nominal ratings of the 23 pumps.

For the three large vacuum vessels (main vacuum chamber, EUV collimator, X-ray collimator), the design is similar :

- \* a primary pumping group made of a rotary vane pump and a roots pump. A liquid nitrogen trap is installed in the tubing between the chamber and the pumps in order to catch the possible contamination coming from the pumps. The associated risk is nevertheless small due to the time these pumps are in use (about 2 hours at the beginning of the pumping sequence).
- \* a turbomolecular group made of a turbomolecular pump on magnetic bearings and a rotary vane pump.
- \* additionally, a cryogenic pump has been installed on the main vacuum chamber and a liquid nitrogen trap (for molecular contamination) is present in the main

chamber and continuously cooled for pressure lower than 1 mbar.

For the vacuum chambers of the sources, only turbomolecular pumping is installed. The primary pumping is done through the turbomolecular pump by a diaphragm pump.

## FOCAL X : pumping system

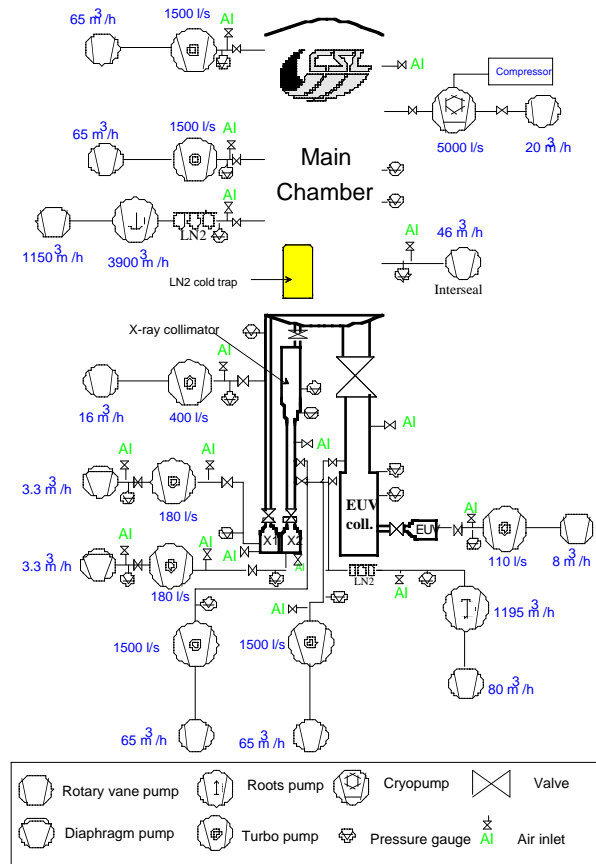

figure 2

In figure 3, the typical pumping curve of the main chamber is given. Starting from atmospheric pressure, a vacuum of  $10^{-3}$  Pa is reached in 4 hours. The volume of the main vacuum chamber is about  $190 \text{ m}^3$ .

The pumping sequence and the pumps choice were driven by two factors : a high pumping speed and no molecular and particulate contamination.

### Main chamber pressure

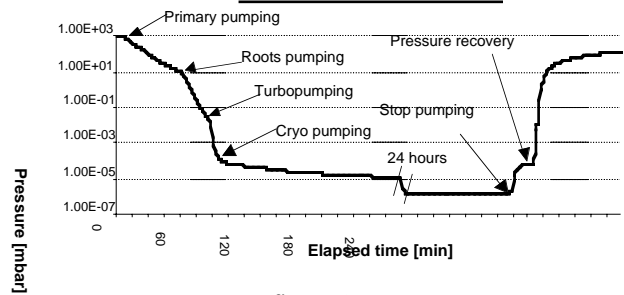

figure 3

### 2.3. EUV channel

The EUV channel is depicted in figure 4 and each item is described hereafter

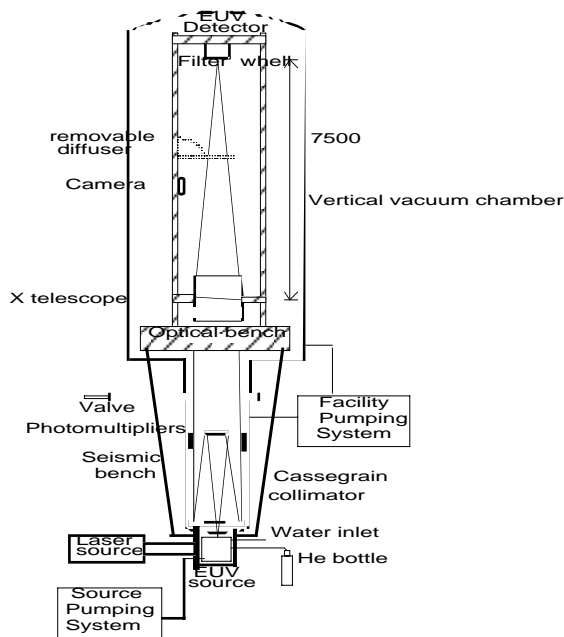

figure 4

#### 2.3.1. EUV source

The EUV source is an Electron Cyclotron Resonance Helium source providing the He I line at 58.4 nm ( $8 \cdot 10^{15}$  ph/sec\*sr) and the He II line at 30.4 nm ( $1 \cdot 10^{15}$  ph/sec\*sr). A 100  $\mu$ m pinhole, installed in front of the source emitting zone, is located at the focus of the collimator

#### 2.3.2. Visible source

A He/Ne laser of 10 mW is used to provide a 633 nm beam. A pinhole, installed in front of the laser, is located at the conjugate focal point of the EUV collimator by means of a removable folding mirror as shown in figure 5.

The visible source is particularly useful for the atmospheric alignment of the telescope because it produces an on line direct image of the telescope, giving the possibility to react in real time. This source could also be used for straylight tests in the FOV and outside the FOV (up to  $7.5^\circ$ ) where attenuation factors might be as high as  $10^6$ . It is clear that a very powerful source is mandatory to perform these measurements in a reasonable time.

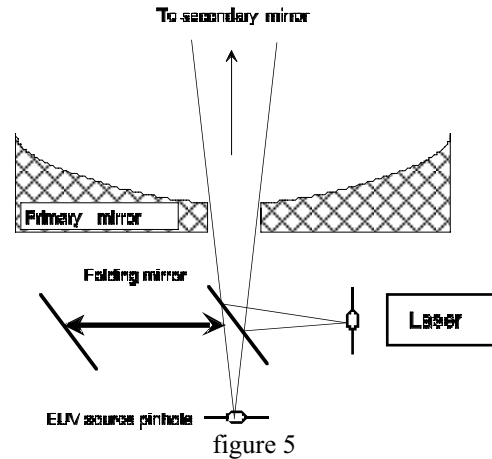

figure 5

#### 2.3.3. EUV collimator

In front of the EUV and visible sources, a Cassegrain collimator provides a 800 mm diameter collimated beam (internal obstruction : 250 mm diameter). Both mirrors are made of Zerodur, Platinum coated with a microroughness better than 10  $\text{\AA}$ . Figure 6 shows an image taken at CSL with an optical profilometer.

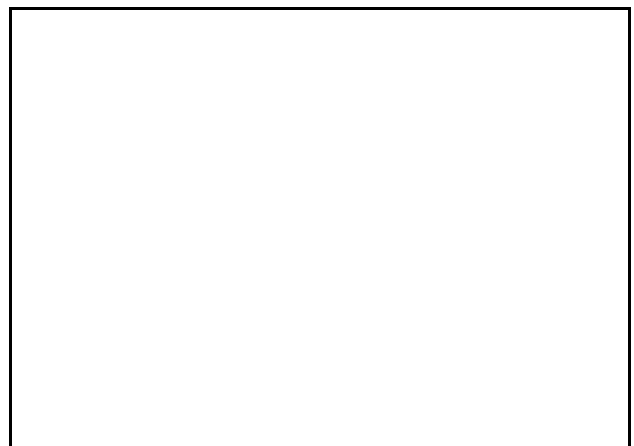

figure 6

This test was performed on the secondary mirror before coating. It was not performed on the primary mirror itself for handling and safety reasons but on its central drilled part, before and after coating. No significant difference was noticed.

#### 2.3.4. Monitoring photo-multipliers

To check stability and homogeneity of the collimated flux, four photo-multipliers are installed, measuring the collimated beam reflected by folding mirrors mounted on the secondary mirror spoke arms, so no additional vignetting is generated. They are working in the visible but the correlation between EUV and visible was checked by scanning the collimated beam with two detectors : one sensitive to visible only and one sensitive to EUV only.

#### 2.3.5. Visible CCD camera

At about 5 meters from the telescope, a remotely removable diffuser is installed in order to see the image at this location (hyperbola focus).

A visible CCD camera with a 70-210 mm zoom is used to visualise the image outside the chamber.

### 2.3.6. EUV CCD camera

In the focal plane, an EUV thinned backside illuminated CCD is installed. It has  $1152 * 770$  pixels<sup>2</sup> of  $22.5 * 22.5 \mu\text{m}^2$ . The working temperature of the CCD is  $-100^\circ\text{C}$ . The detector is cooled via a liquid nitrogen cold plate and the temperature is regulated by heaters inside the camera.

A filterwheel is installed in front of the detector. The different positions are :

Position	Filter	Thickness [microns]	Diameter
1	shutter	/	/
2	aluminium	0.200	8 mm meshfree
3	aluminium	0.150	40 mm with a mesh
4	hole	/	40 mm
5	aluminium	2 * 0.150	8 mm meshfree
6	al-carbon	0.150 (Al) +0.200 (C)	8 mm meshfree

## 2.4. X-ray pencil beam channel

This channel is schematised in figure 7.

### 2.4.1. X-ray source

An X-ray source is installed at the bottom of the channel. The anode of the source is equipped with remotely selectable copper and aluminium targets.

The projected emitting zone of the source is a disc of about 1 mm diameter.

In front of the source, a 18 position filterwheel is installed in order to select the appropriate lines and intensities and, by the way, to reject the visible flux from the source. The following filters are available but other ones could be implemented if necessary.

Position [number]	Material	Thickness [microns]
1	Hole	/
2	Al + Cu	40 + 5
3	Cu	20
4	Cu	50
5	Cu	100
6	Al	6
7	Al	20

8	Al	50
9	Ni	5
10	Ni	20
11	Ni	50
12	Ni	100
13	Cu	500
14	Cu	500
15	Cu	500
16	Stainless steel	1000 (shutter)

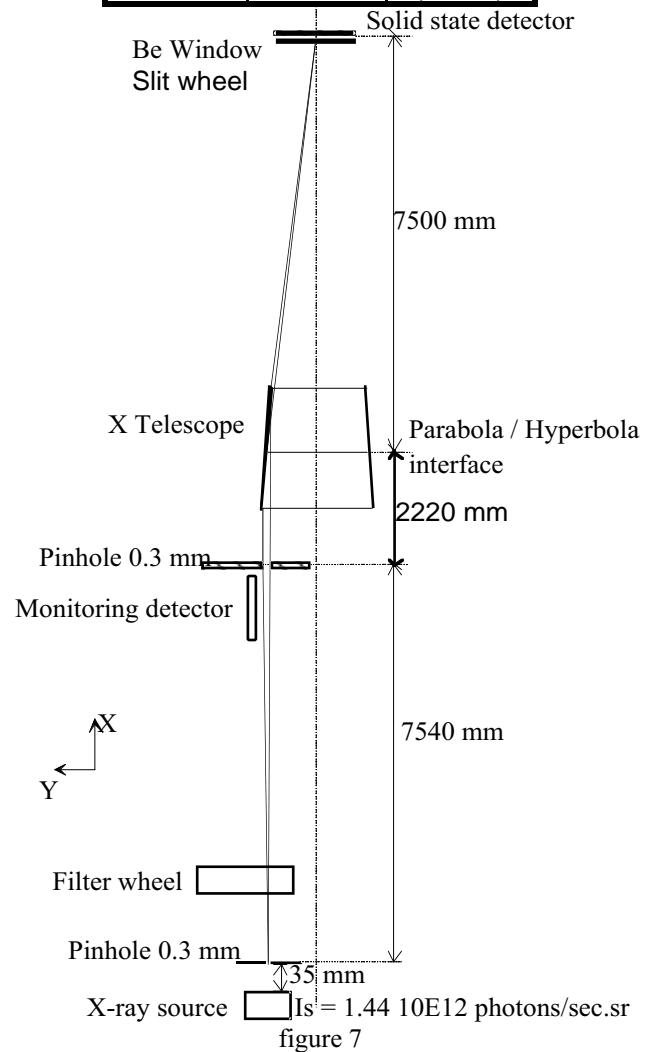

### 2.4.2. Two pinholes system

In front of the X-ray source, two pinholes of 0.3 mm diameter separated by 7540 mm are installed, providing a pencil beam of about 0.5 mm diameter at test specimen level. They are easily accessible and could be changed to tailor the beam shape. The (re-)alignment with respect to gravity is performed thanks to a liquid mirror and a theodolithe.

### 2.4.3. Solid state monitoring detector

A solid state detector is installed between the two pinholes to monitor the source intensity ; its characteristics are:

Crystal : silicium  
Active surface : 7 mm<sup>2</sup>  
Energy resolution : 250 eV at 5.9 keV  
Window : Beryllium  
 12.5 μm thick, meshfree  
Operating temperature : - 25°C  
Cooling : Peltier

A pinhole of 0.3 mm diameter is installed just in front of the detector to work in the middle of its linearity range.

#### 2.4.4. Solid state main detector

In the focal plane, another solid state detector is installed, with the following characteristics :

Crystal : germanium  
Active surface : 500 mm<sup>2</sup>  
Energy resolution : 240 eV at 5.9 keV  
 laboratory conditions  
Window : Beryllium, 20 mm diameter  
 13 μm thick with hexagonal mesh  
Operating temperature : - 150°C  
Cooling : home-made dedicated liquid nitrogen cooling system

This detector having no spatial resolution, a slitwheel has been installed in front of it. As the detector is on a 3-axis translating mechanism, it is possible to scan an image and to reconstruct it. The slit width is 100 μm. In the same wheel, a shutter and a calibration source (Fe 55 giving lines at 5.9 keV and 6.4 keV) are installed to calibrate and check the detector is situ.

### 2.5. X-ray collimated beam channel

This channel is schematised in figure 8.

#### 2.5.1. X-ray source

The X-ray source is the same as the one of the previous channel but the anode is equipped with the following targets :

Target	Quantity	Element number	Energy [keV]
Aluminium	7	13	1.5
Copper	5	29	8.04 8.90
Gold	2	79	2.1
Molybdenum	2	42	2.29
Carbon	2	6	continuous

Availability of other lines must be checked by tests in situ. This kind of anode will be implemented in the other X-ray source in the near future.

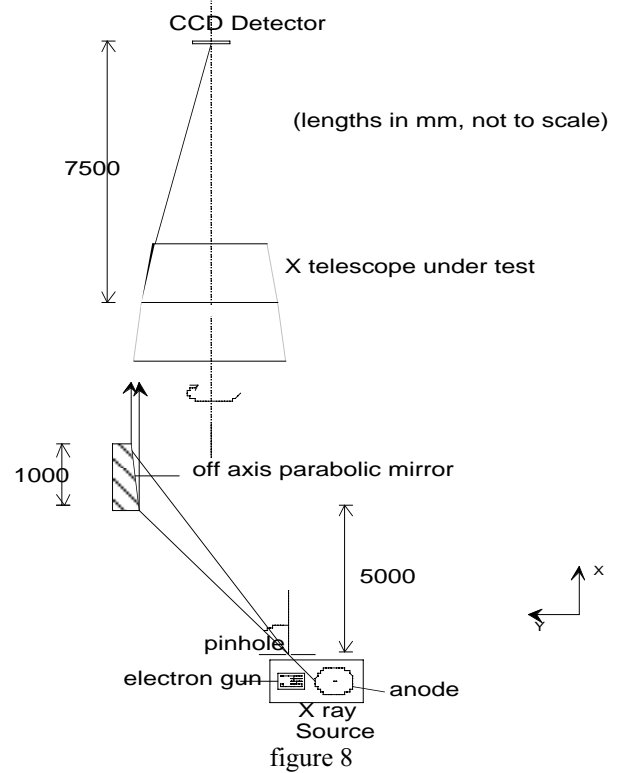

#### 2.5.2. X-ray collimator

In front of the second X-ray source, a Zerodur gold coated off-axis parabolic mirror is aligned, providing a vertical X-ray collimated beam with the shape described in figure 9.

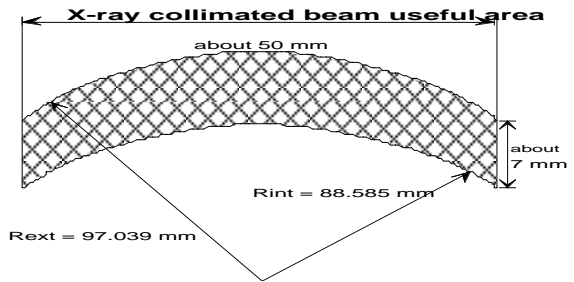

figure 9

A 100 μm diameter pinhole is at the focus of the parabolic mirror and is located inside the source.

The same filterwheel as on the X1 channel is installed between the source and the collimator. At position 14, a Beryllium filter will be soon mounted.

#### 2.5.3. Solid state monitoring detector

In front of the parabolic mirror, in a non-used area, an identical monitoring detector is installed (the same as X-ray pencil beam channel ; see §2.4.3.).

#### 2.5.4. X-ray CCD camera

In the focal plane, an X frontside illuminated CCD is installed. It has 1152 \* 770 pixels<sup>2</sup> of 22.5 \* 22.5 μm<sup>2</sup>. Its working temperature is -100°C and is reached via a liquid nitrogen cold plate and heaters inside the camera itself.

The two X-ray detectors can be placed in front of the two X-ray beams, using the mechanisms.

## 2.6. Mechanisms

Remote controlled mechanisms are installed in the main chamber :

At specimen level :

- \* 2 horizontal translations to position and align the specimen in front of each of the three optical beams.
- \* 1 rotation around the vertical axis (telescope axis)
- \* 2 tilts for alignment and imaging purposes in the FOV.

At detector level :

- \* 3 orthogonal translations
- \* 2 rotation tables under the X CCD and the solid state detector.

## 2.7. Cleanrooms

The overall facility is located in a class 10 000 cleanroom of 28\*18\*15 m<sup>3</sup>. A dedicated class 100 has been built around FOCAL X. A polyethylene tent is mounted on an aluminium frame. Laminar walls are installed at one end. These different items are shown on the figure 10 ; all this area is included in the class 10 000.

## 2.8. Handling tools

A 10 tons crane is working in the class 10 000 allowing heavy handling. In the class 100, a one-axis 2 tons class 100 compatible crane has been installed, allowing the specimen to be loaded on the manipulator and is shown on figure 10.

The manipulator is a two-axis robot designed to introduce and remove the specimen from the vacuum chamber.

## 2.9. Control / Command system

The facility is fully equipped with computerised data handling system. Pumping and cooling systems, mechanisms, temperature and pressure sensors acquisition and data processing together with image acquisition and analysis (on- and off-line) are performed by 3 networked HP9000 workstations. The software used is mainly RTAP for facility control and IDL for image analysis.

The architecture has been designed as a very flexible one to be able to be customised to a very broad range of needs.

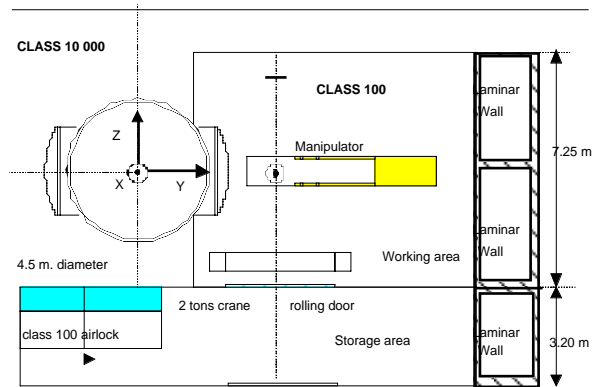

Top view  
figure 10

## 3. CONCLUSIONS

The FOCAL X test facility which has been described and which is presently dedicated to XMM is a powerful test tool for optical test and diagnosis purposes of X-ray telescopes.

Its very flexible design could be adapted to other types of tests and telescopes. The present equipment is also a solid basis for next generation scientific programmes.

## 4. ACKNOWLEDGEMENTS

The authors wish to thank the XMM scientists and particularly Dr. H. Bräuninger and his team from the Max-Planck Institut für Extraterrestrische Physik for their collaboration on the X-ray sources and on other technical aspects.

The vertical facility was funded by ESA XMM project under the ESTEC contract number 9939/92/NL/PP.

## 5. REFERENCES

1. J.P. Collette, C. Jamar "X-ray and Extreme Ultra-Violet Test Facility of the XMM Optics", International Astronautical Federation, Oslo 1995
2. J.P. Collette, Y. Stockman, J.Ph. Tock, Ph. Kletzkine, R. Lainé, A. Vignelles "Performance of XMM Optics vertical test facility", SPIE Denver 1996

Plan :

Introduction

Historic

Components description :

Chambers

Optical stimuli (Various wavelengthes)

Detectors (EUV CCD, X CCD, solid state detector, photo-multipliers, visible CCD

Optics : Cassegrain, off axis parabola, pencil beam

Vacuum systems : operating pressure (3 hours)

Mechanisms : remotely controlled, manipulator

Cleanrooms : class 100, class 10000

Handling tools : crane 10 T, 2 T,

Conclusion